

Flanged Connector Clamps

Aluminum, Split Assembly, with 4 Mounting Holes

SPECIFICATION

Identification no.

No. **2**: With 2 stainless steel socket cap screws DIN 912

Aluminum

- Powder coated
Black, RAL 9005, textured finish **SW**
- Plain finish, matte shot-blasted **BL**

Socket cap screws DIN 912

Stainless steel AISI 304

Hex nuts DIN 985

Stainless steel AISI 304

Self-locking via polyamide ring



INFORMATION

The clamping bore of flanged connector clamps GN 147 is not machined and designed for construction tubes GN 990 (see page 1902) or DIN 2391, DIN 2395 and DIN 2462.

The versions with square bores are also suitable for use with **profile systems**.

At the screw location **z** the socket cap screw reduces the bore cross-section for clamping.

For clamping without tools, the socket cap screws can be replaced by the adjustable hand levers GN 911 (see page 1874) listed in the table as accessories.

ACCESSORY

- Construction Tubes GN 990 (see page 1902)
- Adjustable Hand Levers GN 911 (see page 1874)

TECHNICAL INFORMATION

- Stainless Steel Characteristics (see page A26)

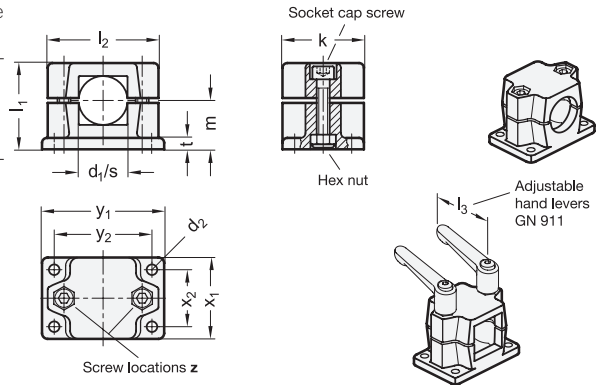

* Complete with

SW RAL9005 Plain **BL**

GN 147-B

Description	d ₁ Bore	d ₂	k Clamping length	l ₁	l ₂	m	t	x ₁	x ₂	y ₁	y ₂	z Screw locations	Accessory Recom. hand lever GN 911 for z l ₃	⚖
GN 147-B20-2-*	B 20	6.5	50	53	68	30	7	50	35	75	60	M8-40	63 78	247
GN 147-B25-2-*	B 25	6.5	50	53	68	30	7	50	35	75	60	M8-40	63 78	240
GN 147-B30-2-*	B 30	6.5	50	53	68	30	7	50	35	75	60	M8-40	63 78	232
GN 147-B40-2-*	B 40	11	76	81.5	98	46.5	14	76	50	115	90	M10-65	78 92	700
GN 147-B42-2-*	B 42	11	76	81.5	98	46.5	14	76	50	115	90	M10-65	78 92	651
GN 147-B45-2-*	B 45	11	76	81.5	98	46.5	14	76	50	115	90	M10-65	78 92	640
GN 147-B48-2-*	B 48	11	76	81.5	98	46.5	14	76	50	115	90	M10-65	78 92	620
GN 147-B50-2-*	B 50	11	76	81.5	98	46.5	14	76	50	115	90	M10-65	78 92	600
GN 147-B60-2-*	B 60	11	90	98	108.5	56	14	90	64	140	113	M10-80	-	580

GN 147-S

Description	S Square	d ₂	k Clamping length	l ₁	l ₂	m	t	x ₁	x ₂	y ₁	y ₂	z Screw locations	Accessory Recom. hand lever GN 911 for z l ₃	⚖
GN 147-V20-2-*	V 20	6.5	50	53	68	30	7	50	35	75	60	M8-40	63 78	242
GN 147-V25-2-*	V 25	6.5	50	53	68	30	7	50	35	75	60	M8-40	63 78	230
GN 147-V30-2-*	V 30	6.5	50	53	68	30	7	50	35	75	60	M8-40	63 78	221
GN 147-V40-2-*	V 40	11	76	81.5	98	46.5	14	76	50	115	90	M10-65	78 92	643
GN 147-V45-2-*	V 45	11	76	81.5	98	46.5	14	76	50	115	90	M10-65	78 92	625
GN 147-V50-2-*	V 50	11	76	81.5	98	46.5	14	76	50	115	90	M10-65	78 92	610
GN 147-V60-2-*	V 60	11	90	98	108.5	56	14	90	64	140	113	M10-80	-	590

Weight SW